

Pneumatic Liquid Level Switch Series: NLS



The Series NLS pneumatic liquid level switch is designed for use in high viscosity liquids. It is modified to overcome the high viscosity by making the tip of the detecting pipe larger than usual. The NLS is the ideal sensor for applications where electrical power is not available or hazardous conditions exist. Using a diaphragm, the switch is actuated by compression of a captive air column in the detecting pipe beneath the diaphragm.

Features

- Low cost - requires only a standard 1/2 in pipe
- Simple installation
- Rugged and reliable
- Long switch life

NLS Specifications

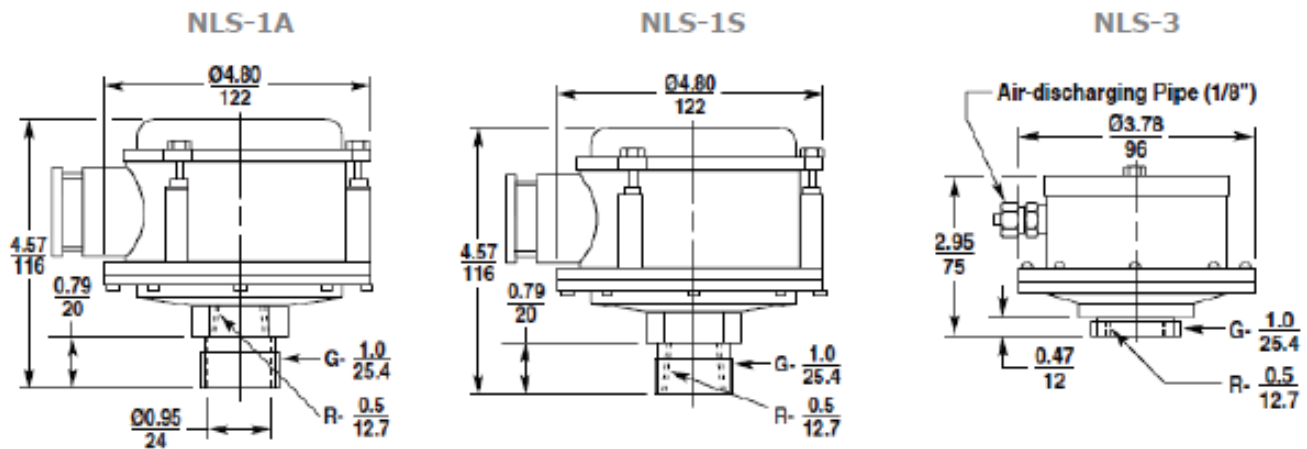

Performance

- SPDT switch
- Detection Range: 8 - 200 in (200 - 5,000 mm)

Connectivity

- Output Contact Rating:
250 V 10 A AC; 115 V 0.5 A DC (resistive)

Certification

- NEMA 4, IP42
- NEMA 1, IP20 (NLS-3)

Physical

- Housing:
ADC12
SS41 (NLS-3)
- Diaphragm: Neoprene®, Viton®

Environmental

- Operating Temperature:
-4° - 158°F (-20° - 70°C)

	NLS-1A	NLS-1S	NLS-3
Water	•	•	•
Oil	•	•	•
Wastewater	•	•	•
Chemicals		•	
Solvents		•	

Model Configuration Options

Model Number: NLS - _____
A

A. Protective Bellows

- 1A** Standard materials (Neoprene®)
- 1S** Corrosive materials (Viton®)
- 3** Indoor, light duty (Neoprene®)